

भारतीय मानक
Indian Standard

IS 5149 : 2020

मलेइक एन्हायड्राईड, तकनीकी की विशिष्टि
(दूसरा पुनरीक्षण)

Specification for Maleic Anhydride,
Technical
(*Second Revision*)

ICS 71.080.50

© BIS 2020



भारतीय मानक ब्यूरो
BUREAU OF INDIAN STANDARDS
मानक भवन, 9 बहादुरशाह ज़फर मार्ग, नई दिल्ली – 110002
MANAK BHAVAN, 9 BAHADUR SHAH ZAFAR MARG
NEW DELHI-110002
www.bis.gov.in www.standardsbis.in

January 2020

Price Group 5

Organic Chemicals, Alcohols And Allied Products Sectional Committee, PCD 09

FOREWORD

This Indian Standard (Second Revision) was adopted by the Bureau of Indian Standards, after the draft finalized by the Organic Chemicals, Alcohols And Allied Products Sectional Committee had been approved by the Petroleum, Coal and Related Products Division Council.

This standard was first published in 1969 and subsequently revised in 1977. As a result of the periodical review of the quality of product available and that specified in Indian as well as overseas standards, the Sectional Committee revised it. In the first revision, the requirements for crystallizing point, colour of molten material, maleic anhydride content and maleic acid content were modified. In accordance with the corresponding ISO recommendation the requirement for colour of the molten material after heat treatment was deleted.

This revision has been taken up mainly to update cross referred standards. Amendment no. 1 of the standard has also been incorporated in this revision.

Maleic anhydride also known as *cis*-butenedioic anhydride, furandione, and toxic anhydride, is used in the manufacture of alkyd resins, drying oils, polyesters, insecticides like malathion, paper sizing and plasticizers.

Maleic anhydride is toxic and exposure to the material during handling should be kept to a minimum (*see 4.1*).

The Indian Standards listed in Annex C which are referred in this standard are informative in nature. All standards are subject to revision and parties to agreement based on standards are encouraged to apply the most recent editions of the standards.

The composition of the Committee, responsible for the formulation of this standard is given at Annex D.

For the purpose of deciding whether a particular requirement of this standard is complied with the final value, observed or calculated, expressing the result of a test or analysis shall be rounded off in accordance with IS 2 : 1960 'Rules for rounding off numerical values (*revised*)'. The number of significant places retained in the rounded off value should be the same as that of the specified value in this standard.

Indian Standard
**SPECIFICATION FOR MALEIC ANHYDRIDE,
TECHNICAL**
(Second Revision)

1 SCOPE

This standard prescribes the requirements and the methods of sampling and test for maleic anhydride, technical, suitable for industrial purposes.

2 REQUIREMENTS

2.1 Description — The material may be either solid or molten. When solid it shall be in the form of white flakes, rods, pallets or briquettes free from any visible impurities.

2.2 The material shall also comply with the requirements given in Table 1 when tested according to the methods prescribed in Annex A. References to the relevant clauses of Annex A are given in column 4 of the Table 1.

3 PRECAUTIONS IN HANDLING

Maleic anhydride is toxic and dangerous decomposition may occur when it is heated with small amounts of caustic or other alkalis, alkaline materials and organic bases. Every reasonable precaution should, therefore, be exercised in its handling, use and storage. Extreme care should be exercised to avoid contact with the skin, inhalation of its dust and vapour and when handling apparatus that has become contaminated with maleic anhydride.

4 PACKING AND MARKING

4.1 The material shall be packed in suitable airtight containers, such as, bottles, steel barrels and tank cars.

4.2.1 Each container shall be securely closed after filling and marked with the following:

- a) Name of the material;
- b) Name of the manufacturer and his recognized trade-mark, if any;
- c) Mass of the material in the container; and
- d) Lot or batch number.

4.2.2 BIS Certification Marking

The product(s) conforming to the requirements of this standard may be certified as per the conformity assessment schemes under the provisions of the *Bureau of Indian Standards Act, 2016* and the Rules and Regulations framed thereunder, and the product(s) may be marked with the Standard Mark.

5 SAMPLING

The method of preparation of test samples and the criteria for conformity shall be as prescribed in Annex B.

Table 1 Requirements for Maleic Anhydride, Technical
(Clause 2.2)

SI No.	Characteristic	Requirement	Method of Test (Ref to Cl No. in Annex A)
(1)	(2)	(3)	(4)
i)	Crystallizing point, °C, <i>Min</i>	52.5	A-2
ii)	Colour of the molten material, Hazen units, <i>Max</i>	20	A-3
iii)	Maleic acid content, percent by mass, <i>Max</i>	0.5	A-4
iv)	Maleic anhydride content, percent by mass, <i>Min</i>	99.5	A-5
v)	Ash, percent by mass, <i>Max</i>	0.005	A-6
vi)	Iron content (as Fe) , parts per million, <i>Max</i>	10	A-7

IS 5149 : 2020

ANNEX A

(Clause 2.2 and Table 1)

METHODS OF TEST FOR MALEIC ANHYDRIDE, TECHNICAL

A-1 QUALITY OF REAGENTS

Unless specified otherwise, pure chemicals and distilled water (see IS 1070) shall be used in tests.

NOTE — 'Pure chemicals' shall mean chemicals that do not contain impurities which affect the results of analysis.

A-2 DETERMINATION OF CRYSTALLIZING POINT

The material is melted and then slowly cooled to determine its crystallizing point by observation of the temperature during crystallization under prescribed conditions.

NOTE — This determination shall be carried out without preliminary dehydration but as soon as possible after the sample is opened as the free acid content increases when the sample is in contact with moist air.

A-2.1 Apparatus

The crystallizing point apparatus shall be as shown in Fig. 1. A thick glass tube of nominal size 100 × 25 mm is placed inside a larger glass tube of nominal size 150 × 50 mm. The latter tube is flanged so that it may be supported centrally by the metal cover plate.

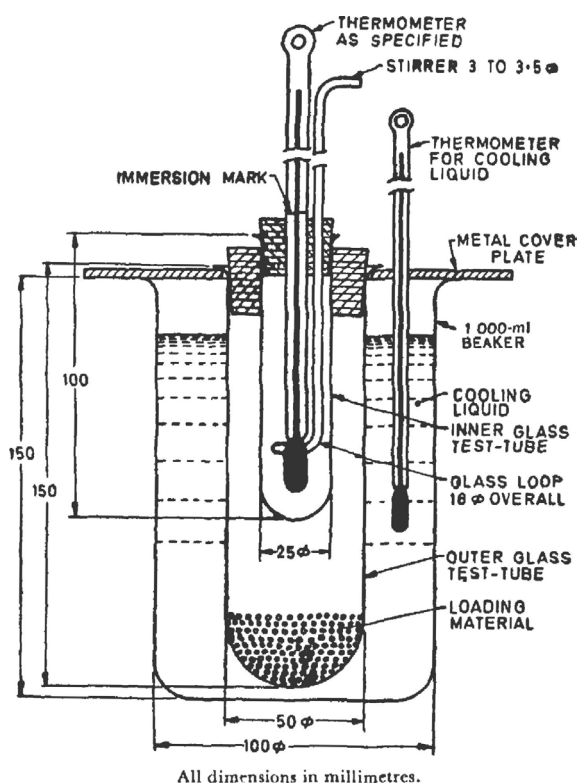

FIG. 1 DETERMINATION OF CRYSTALLIZING POINT

A-2.1.1 The wider tube is weighted with lead shot, or similar material and the inner tube is closed by means of a cork, which carries a glass stirrer and through its centre a standard thermometer. The stirrer is a loop which surrounds the thermometer. The thermometer is so fixed in the cork that the thermometer's immersion mark is in level with the top of the cork and if the thermometer has a contraction chamber, the distance from the bottom of the bulb to the top of the contraction chamber shall not be more than 35 mm.

A-2.1.2 The wider tube is supported in 1 000 ml tall-form beaker filled with cooling liquid to within 20 mm of the top. A thermometer for the cooling bath passes through a hole in the cover plate and is held by a rubber ring.

A-2.1.3 Thermometer

Conforming to the following requirements:

Range	24 to 78°C
Graduated at each	0.2°C
Longer lines	1°C
Immersion	100 mm
Overall length, <i>Max.</i>	385 mm
Stem diameter	5.5 to 8.0 mm
Bulb shape	Cylindrical
Bulb length	15 to 20 mm
Length of main scale, <i>Min.</i>	190 mm
Distance from bottom of bulb to bottom of main scale, <i>Min.</i>	125 mm
Error, <i>Max.</i>	± 0.2°C

NOTE — Any thermometer of convenient range and similar requirements and accuracy may be used.

A-2.1.3.1 The thermometer shall bear a certificate from the National Physical Laboratory, New Delhi or any other institution authorized by the Government of India to issue such a certificate.

A-2.2 Procedure

Remove the inner tube from the crystallizing point apparatus and introduce about 30 g of the material for test. Warm the tube in a bath at about 60°C until all but last traces of crystals are melted. Replace the inner tube in its jacket with the cooling liquid in the apparatus maintained at 45 to 47°C. Stir the material gently and continuously and record thermometer readings at 30 s intervals, make sure that a seed crystal is present as the temperature of the material falls to that at which crystallization commences.

The crystallizing point corresponds to the highest of the first five consecutive readings (corrected for thermometer error) during which the temperature remains constant within 0.1°C.

A-2.2.1 If super cooling occurs, as shown by a rise in temperature, observe the constant temperature after the rise. If five consecutive readings within 0.1°C are not obtained, record six readings commencing with the point at which the maximum temperature is first attained. Plot the complete cooling curve of temperature against time and draw a straight line to lie evenly between the first and second and between the fifth and sixth points mentioned above. Extend this line to meet the section of the cooling curve before the temperature rise. Report the temperature corresponding to the point of intersection, corrected for thermometer error, as the crystallizing point.

A-3 MEASUREMENT OF COLOUR OF THE MOLTEN MATERIAL

The material is melted and the colour of the molten material is compared with that of the permanent colour standard and expressed in terms of hazen colour units. [The Hazen colour unit is defined as the colour of an aqueous solution containing 1 part per million of platinum in the form of chloroplatinic acid and 2 parts per million of cobalt chloride (CoCl₂.6H₂O)].

A-3.1 Apparatus

A-3.1.1 *Identical Flat-Based Calorimetric Tubes, (Two)* — Heat resistant and approximately 20 mm in external diameter and having a graduation mark 100 mm above the base.

A-3.1.2 *One-Mark Graduated Flasks* — Of 500 ml and 250 ml capacities (see IS 915).

A-3.1.3 *Electrically-Heated Aluminium Block* — Capable of maintaining temperature at 65 ± 3°C with holes 22 mm in diameter and at least 120 mm in depth such that the flat-based tubes project above the surface of the block.

A-3.2 Reagents

A-3.2.1 *Cobaltous Chloride Hexahydrate*

A-3.2.2 *Hydrochloric Acid*

Relative density 1.16 (see IS 265).

A-3.2.3 *Chloroplatinic Acid*

Dissolve 250 mg of platinum in a small quantity of aqua regia contained in a glass or porcelain basin by heating on a water bath. When the metal has dissolved, evaporate the solution to dryness. Add 1 ml of hydrochloric acid and again evaporate to dryness. Repeat the operation twice more.

A-3.2.4 *Potassium Chloroplatinate*

A-3.3 Preparation of Colour Standard

Dissolve 0.50 g of cobaltous chloride hexahydrate and the whole of the chloroplatinic acid (see A-3.2.3) or 0.6225 g of potassium chloroplatinate in 50 ml of hydrochloric acid. Warm, if necessary, to obtain a clear solution and, after cooling, pour into the 500 ml one mark graduated flask. Dilute with water up to the graduation mark.

Pipette 10 ml of this solution into 250-ml one-mark graduated flask. Dilute with water up to the graduation mark. This diluted solution is equivalent to 20 Hazen units and should always be freshly prepared.

A-3.4 Procedure

A-3.4.1 Introduce into one of the colorimetric tubes (see A-3.1.1) a quantity of the material sufficient to reach graduation mark after melting. Pour the specified Hazen colour standard into the other tube to the mark.

A-3.4.2 Place the tube containing the material in the electrically heated block maintained at 65 ± 3°C (see A-3.1.4) and as soon as it is melted compare the colour with that of the specified Hazen colour standard against a white background.

A-3.4.2.1 The material shall be taken to have passed the test if the intensity of the colour of the material is not more than that of the colour standard.

A-4 DETERMINATION OF MALEIC ACID CONTENT

The material is dissolved in ethyl methyl ketone and titrated with standard triethylamine solution using bromophenol blue as indicator. Maleic acid content is then calculated from the amount of standard triethylamine solution used up.

NOTE — This determination shall be carried out immediately after the sample is opened as the maleic acid content increases when the material is in contact with moist air.

A-4.1 Reagents

A-4.1.1 *Phthalic Acid*

A-4.1.2 *Ethyl Methyl Ketone*

Neutralized to bromophenol blue by addition of an approximately 0.1 N solution of triethylamine in ethyl methyl ketone and containing not more than 0.1 percent (m/m) of water.

NOTE — Sufficiently dry ethyl methyl ketone may be obtained by refluxing over calcium chloride for approximately 3 hours followed by decantation and distillation.

A-4.1.3 *Bromophenol Blue Indicator*

Dissolve 0.1 g of bromophenol blue in 100 ml of ethyl methyl ketone.

IS 5149 : 2020

A-4.1.4 Standard Triethylamine Solution (in Ethyl Methyl Ketone)

0.1 N; standardize as follows:

Weigh accurately about 0.1 g of phthalic acid. Dissolve in 50 ml of the ethyl methyl ketone contained in a 150 ml conical flask. Add 0.5 ml of the bromophenol blue indicator and titrate with standard triethylamine solution until the colour changes from green to bluish purple. The factor (F) for the standard triethylamine solution shall be:

$$F = \frac{M_1}{0.1661 V_1}$$

Where,

M_1 = mass in g, of phthalic acid taken, and

V_1 = volume in ml, of standard triethylamine solution used.

A-4.2 Procedure

Weigh accurately about 10 g of the material and dissolve without heating in 150 ml of ethyl methyl ketone contained in a 500 ml flask. Add 1 ml of bromophenol blue indicator and titrate with standard triethylamine solution until the colour changes from green to blue.

A-4.3 Calculation

$$\text{Maleic acid content, percent by mass} = \frac{11.61 \times V \times F}{M}$$

Where,

V = volume in ml, of standard triethylamine solution used,

F = factor for the standard triethylamine solution, and

M = mass in g, of the material taken for the test.

A-5 DETERMINATION OF MALEIC ANHYDRIDE CONTENT

The maleic anhydride content is determined by titrating the material with standard sodium hydroxide solution using phenolphthalein as indicator and deducting the maleic anhydride content equivalent to maleic acid content as determined under A-4.

NOTE — This determination shall be carried out as soon as possible after the sample is opened as the maleic anhydride content decreases when the sample is in contact with moist air.

A-5.1 Reagents

A-5.1.1 Potassium Hydrogen Phthalate — Previously dried for 2 h at 120°C.

A-5.1.2 Phenolphthalein Indicator — Dissolve 0.5 g of phenolphthalein in 100 ml of rectified spirit (*see* IS 323). Add standard sodium hydroxide solution until the indicator is faintly pink.

A-5.1.3 Standard Sodium Hydroxide Solution — 0.5 N; standardize as follows:

Weigh to the nearest milligram about 4 g of potassium hydrogen phthalate and transfer to a 500-ml conical flask. Add 120 ml of water and dissolve by warming on a water bath. Add three drops of the phenolphthalein indicator and titrate hot (above 60°C) with standard sodium hydroxide solution (0.5 N) to the first pink colour. The factor (F) for 0.5 N standard sodium hydroxide solution will be:

$$\frac{M_1}{0.2042 \times V_1}$$

M_1 = mass in g, of potassium hydrogen phthalate taken, and

V_1 = volume in ml, of standard sodium hydroxide solution.

A-5.2 Procedure

Weigh accurately about 1 g of the material into a 250 ml conical flask. Add 35 ml of standard sodium hydroxide solution from a burette and 35 ml of water. Warm gently until the material dissolves. Add three drops of the phenolphthalein indicator and complete the neutralization with standard sodium hydroxide solution until the pink colour is obtained.

A-5.3 Calculation

$$\text{Maleic anhydride content} = \frac{4.0902V \times F}{M} - 0.845A$$

Where,

V = volume in ml, of standard sodium hydroxide solution;

F = factor for standard sodium hydroxide solution (*see* A-5.1.3);

A = maleic acid content, percent by mass (*see* A-4); and

M = mass in g of the material taken for the test.

A-6 DETERMINATION OF ASH

A-6.1 Apparatus

A-6.1.1 Platinum or Silica Basin

A-6.1.2 Furnace — Capable of maintaining temperature within 600 ± 25°C.

A-6.2 Procedure

Weigh accurately about 50 g of the material in a tared platinum or silica basin, slowly burn the material and finally ignite it in a furnace at 600 ± 25°C until all carbonaceous matter has disappeared. Cool in a desiccator and weigh. Retain the residue for the determination of iron content.

A-6.3 Calculation

$$\text{Ash, percent by mass} = \frac{100M}{M_1}$$

Where,

M = mass in g, of the residue after ignition, and

M_1 = mass in g, of the material taken for the test.

A-7 DETERMINATION OF IRON CONTENT

A-7.1 Method A (Volumetric Method)

A-7.1.0 Outline of the Method

The residue obtained after ignition (*see A-6.2*) is dissolved and the iron content is determined using 2,2'-bipyridyl, which gives a red coloured complex with ferrous iron.

A-7.1.1 Apparatus

A-7.1.1.1 One-mark graduated flasks — 1 000 ml and 250 ml capacities (*see IS 915*).

A-7.1.1.2 Nessler cylinders — Two; 100 ml capacity (*see IS 4161*).

A-7.1.2 Reagents

A-7.1.2.1 Hydrochloric acid — Relative density 1.16 (*see IS 265*).

A-7.1.2.2 Dilute sulphuric acid — Add carefully, with stirring, one volume of sulphuric acid (*see IS 266*) to six volumes of water.

A-7.1.2.3 Dilute nitric acid — Dilute one volume of nitric acid (*see IS 264*) with 3 volumes of water.

A-7.1.2.4 Urea solution — Dissolve 100 g of urea in 100 ml of water.

A-7.1.2.5 Hydroxylammonium chloride solution — Dissolve 100 g of hydroxylammonium chloride in 1000 ml of water.

A-7.1.2.6 Ammonium acetate solution — Dissolve 50 g of ammonium acetate in 100 ml of water.

A-7.1.2.7 2,2'-Bipyridyl solution — Dissolve 0.5 g of 2,2'-bipyridyl in 100 ml of dilute hydrochloric acid (1N).

A-7.1.2.8 Standard iron solution — Dissolve 0.7022 g of ammonium ferrous sulphate $[(\text{NH}_4)_2\text{SO}_4 \cdot \text{FeSO}_4 \cdot 6\text{H}_2\text{O}]$ in 50 ml of dilute sulphuric acid and then transfer to one of the 1000-ml one-mark graduated flasks. Dilute with water to 1 000 ml mark. Pipette out 100 ml of this solution into the second 1 000 ml one-mark graduated flask and again dilute this solution with water to 1 000 ml mark. One millilitre of this diluted solution contains 10 μg of iron.

A-7.1.3 Procedure

To the platinum or silica basin containing the residue from the determination of ash (*see A-6.2*), add 5 ml of hydrochloric acid. Heat the basin on a boiling water bath, agitating with a stirrer of platinum wire until all the residue has dissolved. Allow to cool and transfer the solution to a 250 ml one-mark graduated flask. Dilute to the mark with water and mix thoroughly. For each determination, transfer 10 ml of this solution to a 100 ml Nessler cylinder, add 2 ml of urea solution, stir, add 2 ml of hydroxyl ammonium chloride solution, mix and allow to stand for two minutes. Then add 30 ml of ammonium acetate solution and 5 ml of 2,2'-bipyridyl solution. Dilute to 100 ml mark and mix thoroughly.

A-7.1.3.1 To about 55 ml of water in the second Nessler cylinder add 5 ml of dilute nitric acid, then 2 ml of urea solution followed by 2 ml of hydroxylammonium chloride solution, 30 ml of ammonium acetate solution and 5 ml of 2,2'-bipyridyl solution. Add standard iron solution slowly from a burette shaking with each addition, until the depth of the colour in the two cylinders is identical when they are viewed along their axes. Record the volume of standard iron solution added.

A-7.1.4 Calculation

$$\text{Iron (as Fe), parts per million} = \frac{25 \times V}{M}$$

Where,

V = volume in ml, of standard iron solution, and

M = mass in g, of the material taken for ash determination (*see A-6.2*).

A-7.2 Method B (Spectrophotometric or Photoelectric Absorptio-metric Method)

A-7.2.0 Outline of Method

The residue obtained after ignition (*see A-6.2*) is dissolved and the iron content is determined photometrically using 2,2'-bipyridyl, which gives a red coloured complex with ferrous iron.

A-7.2.1 Apparatus

A-7.2.1.1 Spectrophotometer or photoelectric absorptiometer

A-7.2.1.2 Stirrer of platinum wire

A-7.2.1.3 One-mark graduated flasks — Eight, 100 ml capacity.

A-7.2.2 Reagents — Same as in A-7.1.2.

A-7.2.3 Preparation of the Calibration Curve

Place into seven 100 ml one mark volumetric flasks the following quantities of standard iron solution: 0, 2.0, 4.0, 7.0, 10.0, 15.0 and 20.0 ml. To each add 20 ml

IS 5149 : 2020

of the nitric acid solution, 2 ml of the urea solution, and 2 ml of the hydroxyl ammonium chloride solution. Mix and allow to stand for 2 min. Then add 30 ml of the ammonium acetate solution and 5 ml of the 2,2'-bipyridyl solution. Dilute to the mark and mix thoroughly.

Measure the optical densities of the solutions in the spectrophotometer or the photoelectric absorptiometer, determining the optical density at a wavelength between 510 and 520 nm.

Prepare a calibration chart plotting optical densities as a function of the quantities of iron, in micrograms, in 100 ml of the solution.

A-7.2.4 Procedure

To the platinum or silica basin containing the residue from the determination ash (*see A-6.2*), add 5 ml of the hydrochloric acid solution. Heat the basin on a boiling water bath, agitating with the platinum wire stirrer until all the residue has dissolved. Allow to cool and transfer the solution quantitatively with water to

a 100 ml one-mark volumetric flask. Add 2 ml of the urea solution, stir, add 2 ml of the hydroxylammonium chloride solution, mix and allow to stand for 2 min. Then add 30 ml of the ammonium acetate solution, 5 ml of the 2,2'-bipyridyl solution, dilute to the mark and mix thoroughly.

Measure the optical density of the solution in the spectrophotometer or the photoelectric absorptiometer at a wavelength between 510 and 520 nm and, by reference to the calibration curve prepared as in, read the iron content, in micrograms, in 100 ml corresponding to this optical density.

A.7.2.5 Calculation

Iron content (as Fe), parts per million = $\frac{M_1}{M_2}$

Where,

M_1 = mass in micrograms, of iron found, and

M_2 = mass in grams, of the test portion taken for the determination of ash (*see A-6.2*).

ANNEX B

(Clause 5)

SAMPLING OF MALEIC ANHYDRIDE, TECHNICAL

B-1 GENERAL REQUIREMENTS OF SAMPLING

In drawing, preparing, storing and handling test samples, the following precautions and directions shall be observed.

B-1.1 Samples shall be taken in a protected place not exposed to damp air, dust or soot.

B-1.2 Sampling instrument shall be clean and dry.

B-1.3 Precautions shall be taken to protect the samples, the material being sampled, the sampling instrument and the containers for samples from adventitious contamination (*see* also **3.1**).

B-1.4 To draw a representative sample, the contents of each container, selected for sampling shall be mixed, as thoroughly as possible, by suitable means.

B-1.5 The samples shall be placed in clean, dry and airtight glass or other suitable containers on which the material has no action.

B-1.6 The sample containers shall be of such a size that they are almost completely filled by the sample.

B-1.7 Each sample container shall be sealed airtight after filling and marked with full details of sampling, the date of sampling, and other details given under **4.2**.

B-1.8 Samples shall be stored in a cool and dry place.

B-2 SAMPLING INSTRUMENT

B-2.1 The sampling instrument is a closed type sampling tube, undivided (Fig. 2), consisting of two concentric cylindrical tubes made of a metal which is not affected by the material being sampled (preferably of stainless steel) closely fitting into each other throughout their entire length so that it is possible to rotate one tube within the other, a suitable handle being provided for the purpose. Longitudinal openings of about one-third the circumference are cut in both tubes throughout their length. In one position the two openings coincide and admit the material into the hollow inner tube. By rotating the inner tube through 180° the opening is tightly closed and a 'core' of material being enclosed therein may be withdrawn. This type of sampler is usually provided with a locking arrangement so that the tubes are held together in any desired position. The outer tube is provided with a sharp conical end to facilitate penetration but the base of the cone shall be closed so that no material is entrapped in this portion.

The height of the cone shall be equal to its base diameter. The whole instrument shall be of sufficient length to penetrate an entire diagonal of the container being sampled. The diameter of the inner cylindrical space may vary from 20 to 40 mm proportionately to the length. A length of 150 cm and a diameter of 30 mm can cater for most needs.

B-2.1.1 Use of Sampling Instrument

The instrument is inserted in closed position in an oblique direction till it touches bottom. The material is admitted by rotating and opening the tubes and finally closing them, withdrawing the sample in this process. In case the minimum quantity of material required for test from each container is more than the capacity of the instrument, further 'cores' shall be taken from different parts of the same container such that they are at least 75 mm in the case of drums, bags, etc, and 25 mm in the case of small containers, from the wall of the container. In all cases the instrument shall be inserted till it touches bottom so that an entire cross section is withdrawn.

B-3 SCALE OF SAMPLING

B-3.1 Lot

All the containers in a single consignment of the material drawn from a single batch of manufacture shall constitute a lot. If a consignment is declared or known to consist of containers pertaining to different batches of manufacture, the containers belonging to the same batch of manufacture shall be grouped together and each such group shall constitute a separate lot.

B-3.2 For ascertaining the conformity of lot to the requirements of this specification, tests shall be carried out for each lot separately. The number (*n*) of containers to be selected for drawing the samples shall depend upon the size of the lot and shall be in accordance with Table 2.

B-3.3 These containers shall be selected at random from the lot and in order to ensure the randomness of selection random sampling procedures given in IS 4905 may be followed.

B-4 TEST SAMPLE AND REFEREE SAMPLE

B-4.1 From each of the containers selected according to **B-3.2**, a representative portion of the material, about 100 g, shall be drawn. These samples shall constitute individual samples.

IS 5149 : 2020

Table 2 Number of Containers to Be Selected for Sampling
(Clause B-3.2)

Lot Size (<i>N</i>)	No. of Containers to be Selected (<i>n</i>)
(1)	(2)
4 to 25	3
26 to 50	4
51 to 100	5
101 to 150	6
151 to 300	7
301 and above	8

NOTE — When the size of the lot is three or less, all the containers shall be sampled.

B-4.2 From each of these individual portions (**B-4.1**), and equal quantity of the material shall be taken and thoroughly mixed to constitute a composite sample not less than 600 g. The composite sample shall be transferred to clean bottles and labelled with full identification particulars of the sample. This composite sample shall be divided into three equal parts, one for the purchaser, another for the supplier and the third to be used as a referee sample.

B-5 NUMBER OF TESTS

Tests for the determination of all the characteristics given in Table 1 shall be carried out on the composite sample.

B-6 CRITERIA FOR CONFORMITY

For declaring the conformity of the lot the requirements of all the characteristics, the test results on the composite sample shall meet the corresponding requirement specified.

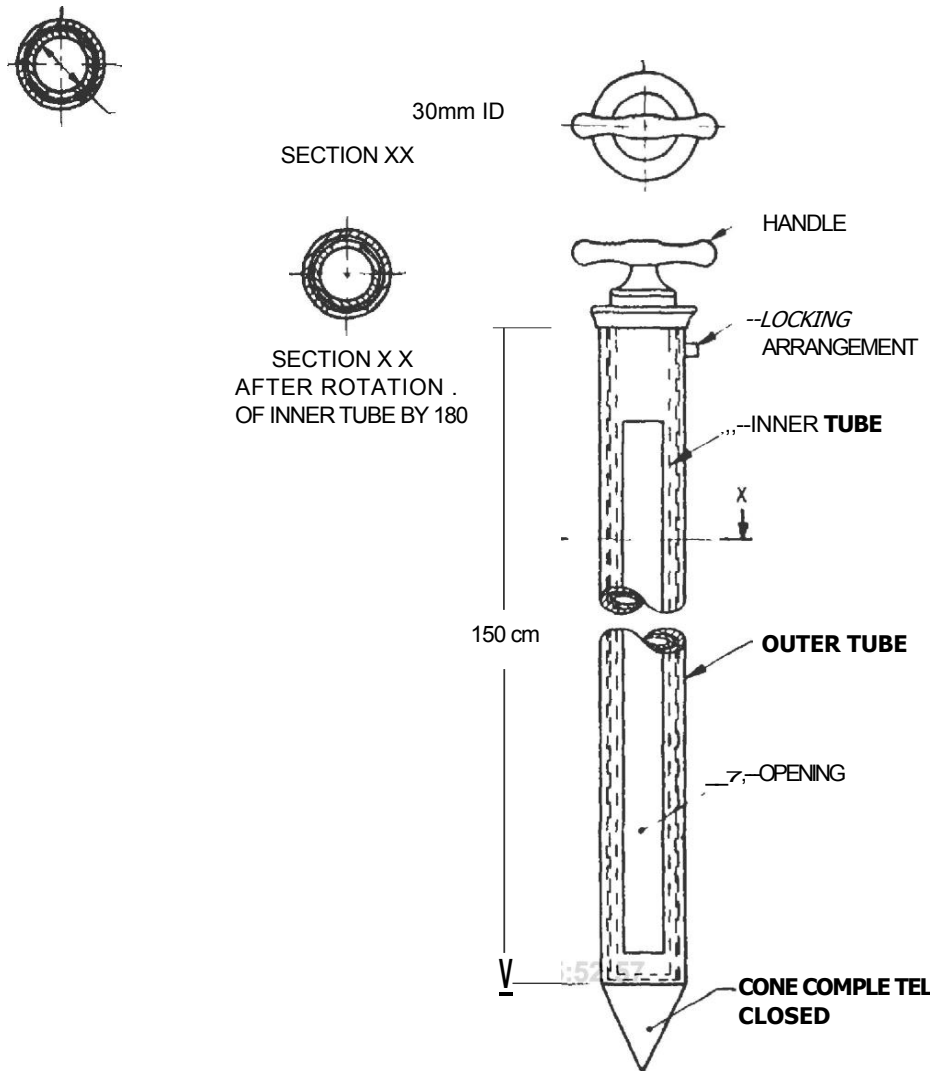

FIG. 2 CLOSED TYPE SAMPLING TUBE, UNDIVIDED

ANNEX C

(Foreword)

LIST OF REFERRED INDIAN STANDARDS

<i>IS No.</i>	<i>Title</i>	<i>IS No.</i>	<i>Title</i>
264 : 2005	Nitric acid — Specification (<i>third revision</i>)	915 : 2012/ ISO 1042 : 1998	Laboratory glassware — One- mark volumetric flasks (<i>third revision</i>)
265 : 1993	Hydrochloric acid — Specification (<i>fourth revision</i>)	1070 : 1992	Reagent grade water — Specification (<i>third revision</i>)
IS 266 : 1993	Sulphuric acid — Specification (<i>third revision</i>)	4161 : 1967	Specification for Nessler cylinders
IS 323 : 2009	Rectified spirit for industrial use — Specification (<i>second revision</i>)	4905 : 2015/ ISO 24153 : 2009	Random sampling and randomization procedures (<i>first revision</i>)

IS 5149 : 2020

ANNEX D

(Foreword)

COMMITTEE COMPOSITION

Organic, Chemicals Alcohols and Allied Products Sectional Committee PCD 09

<i>Organization</i>	<i>Representative(s)</i>
Chemical Engineering and Process Development Division, NCL PUNE	DR C. V. RODE (Chairman)
All India Distilleries Association (AIDA), New Delhi	SHRI V. N. RAINA
Central Drug Research Institute (CDRI), Lucknow	DR SANJEEV KANOJIYA
Central Revenues Control Laboratory, Delhi	DR T. A. SREENIVASA RAO
Chemical and Petrochemicals Manufacturers Association (CPMA), New Delhi	SHRI KAMAL NANAVATY
Indian Chemical Council, Mumbai	DR MRITUNJAY CHAUBEY SHRI J. I. SEVAK (<i>Alternate</i>)
Jubilant life Sciences Ltd, Noida	SHRI HARI MOHAN LOHANI
National Chemical Laboratory, Pune	DR UDAYA KIRAN MARELLI
UPL Limited Mumbai	MR M. D. VACHHANI, GM (QA)
Alkyl Amines Chemicals Ltd, Mumbai	SHRI S. V. NIKUMBHE SHRI SAMEER KATDARE (<i>Alternate</i>)
All India Alcohol-Based Industries Development Association (AABIDA), Mumbai	SHRI K. L. RAPHAEL SHRI KIRTI GAJJAR (<i>Alternate</i>)
Godavari Biorefineries Ltd, Mumbai	SHRI.SHANUL LAXMANRAO PAGAR WANI A. J. (<i>Alternate</i>)
Hindustan Organic Chemicals Ltd (HOCL), Mumbai	DR P. N. KUTTY SHRI P. Y. PATIL (<i>Alternate</i>)
India Glycols Limited, Uttarakhand	SHRI S. R. SONI SHRI ALOK SINGHAL (<i>Alternate</i>)
Laxmi Organic Industries, Mumbai	SHRI J. P. SURYAVANSHI DR VIJAY S. MISHRA (<i>Alternate</i>)
Ministry of Chemicals & Fertilizers, New Delhi	SHRI SANJAY BANSAL SHRI JASBIR SINGH (<i>Alternate</i>)
National Test House, Ghaziabad	SHRI DEBASHIS SAHA DR GOPAL KRISHAN (<i>Alternate</i>)
BIS Director General, New Delhi	SHRI V. K. DIUNDI, SCIENTIST 'F' AND HEAD (PCD) [REPRESENTING DIRECTOR GENERAL (<i>Ex-officio</i>)]

Member Secretary

SHRI CHANDRAKESH SINGH
SCIENTIST 'C' (PCD), BIS

Bureau of Indian Standards

BIS is a statutory institution established under the *Bureau of Indian Standards Act, 2016* to promote harmonious development of the activities of standardization, marking and quality certification of goods and attending to connected matters in the country.

Copyright

BIS has the copyright of all its publications. No part of these publications may be reproduced in any form without the prior permission in writing of BIS. This does not preclude the free use, in the course of implementing the standard, of necessary details, such as symbols and sizes, type or grade designations. Enquiries relating to copyright be addressed to the Director (Publications), BIS.

Review of Indian Standards

Amendments are issued to standards as the need arises on the basis of comments. Standards are also reviewed periodically; a standard along with amendments is reaffirmed when such review indicates that no changes are needed; if the review indicates that changes are needed, it is taken up for revision. Users of Indian Standards should ascertain that they are in possession of the latest amendments or edition by referring to the latest issue of 'BIS Catalogue' and 'Standards: Monthly Additions'.

This Indian Standard has been developed from Doc No.: PCD 09 (14526).

Amendments Issued Since Publication

Amend No.	Date of Issue	Text Affected

BUREAU OF INDIAN STANDARDS

Headquarters:

Manak Bhavan, 9 Bahadur Shah Zafar Marg, New Delhi 110002
Telephones: 2323 0131, 2323 3375, 2323 9402

Website: www.bis.gov.in

Regional Offices:

	Telephones
Central : Manak Bhavan, 9 Bahadur Shah Zafar Marg NEW DELHI 110002	{ 2323 7617 2323 3841
Eastern : 1/14 C.I.T. Scheme VII M, V.I.P. Road, Kankurgachi KOLKATA 700054	{ 2337 8499, 2337 8561 2337 8626, 2337 9120
Northern : Plot No. 4-A, Sector 27-B, Madhya Marg CHANDIGARH 160019	{ 265 0206 265 0290
Southern : C.I.T. Campus, IV Cross Road, CHENNAI 600113	{ 2254 1216, 2254 1442 2254 2519, 2254 2315
Western : Manakalaya, E9 MIDC, Marol, Andheri (East) MUMBAI 400093	{ 2832 9295, 2832 7858 2832 7891, 2832 7892

Branches : AHMEDABAD. BENGALURU. BHOPAL. BHUBANESHWAR. COIMBATORE.
DEHRADUN. DURGAPUR. FARIDABAD. GHAZIABAD. GUWAHATI.
HYDERABAD. JAIPUR. JAMMU. JAMSHEDPUR. KOCHI. LUCKNOW.
NAGPUR. PARWANOO. PATNA. PUNE. RAIPUR. RAJKOT. VISAKHAPATNAM.